

HC4187

40V P-Channel MOSFET

General Description

These P-Channel enhancement mode power field effect transistors are using trench DMOS technology. This advanced technology has been especially tailored to minimize on-state resistance, provide superior switching performance, and withstand high energy pulse in the avalanche and commutation mode. These devices are well suited for high efficiency fast switching applications.

Features

V_{DS}	-40V
I_D (at $V_{GS}=-10V$)	-30A
$R_{DS(ON)}$ (at $V_{GS}=-10V$)	32mΩ(Max)
$R_{DS(ON)}$ (at $V_{GS}=-4.5V$)	45mΩ(Max)

100% UIS TESTED!
100% ΔVds TESTED!

TO252

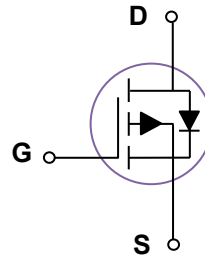
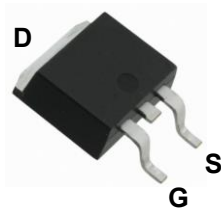

Absolute Maximum Ratings $T_A=25^\circ\text{C}$ unless otherwise noted

Parameter	Symbol	Maximum	Units
Drain-Source Voltage	V_{DS}	-40	V
Gate-Source Voltage	V_{GS}	± 20	V
Drain Current-Continuous	TC=25°C	I_D -30	A
	TC=100°C	I_D -18	A
Drain Current – Pulsed	I_{DM}	-120	A
Single pulse avalanche energy	E_{AS}	87	mJ
Maximum Power Dissipation	P_D	38	W
Junction and Storage Temperature Range	T_J, T_{STG}	-55 To 150	°C

Thermal Characteristics

Parameter	Symbol	Typ	Max	Unit
Thermal Resistance junction-case	$R_{\theta Jc}$		3.6	°C /W
Thermal Resistance junction-to-Ambient	$R_{\theta JA}$		62	°C /W

Electrical Characteristics (T_J=25°C unless otherwise noted)

Symbol	Parameter	Condition	Min	Typ	Max	Unit
STATIC PARAMETERS						
BV_{DSS}	Drain-Source Breakdown Voltage	$V_{GS}=0V, I_D=-250\mu A$	-40			V
I_{DSS}	Zero Gate Voltage Drain Current	$V_{DS}=-40V, V_{GS}=0V$			1	μA
I_{GSS}	Gate-Body Leakage Current	$V_{GS}=\pm 20V, V_{DS}=0V$			± 100	nA
$V_{GS(th)}$	Gate Threshold Voltage	$V_{DS}=V_{GS}, I_D=-250\mu A$	-1.0	-1.6	-2.5	V
$R_{DS(ON)}$	Drain-Source On-State Resistance	$V_{GS}=-10V, I_D=-10A$		25	32	m Ω
		$V_{GS}=-4.5V, I_D=-8A$		35	45	m Ω
DYNAMIC PARAMETERS						
C_{ISS}	Input Capacitance	$V_{DS}=-20V, V_{GS}=0V,$ $F=1.0MHz$		1320		pF
C_{OSS}	Output Capacitance			116		pF
C_{RSS}	Reverse Transfer Capacitance			89		pF
SWITCHING PARAMETERS						
$t_{d(on)}$	Turn-on Delay Time	$V_{DS}=-20V, I_D=-1A,$ $V_{GS}=-10V,$ $R_G=6\Omega$		12.8		nS
t_r	Turn-on Rise Time			8.7		nS
$t_{d(off)}$	Turn-Off Delay Time			65		nS
t_f	Turn-Off Fall Time			12.6		nS
Q_g	Total Gate Charge	$V_{DS}=-20V, I_D=-10A$ $, V_{GS}=-4.5V$		23		nC
Q_{gs}	Gate-Source Charge			2.9		nC
Q_{gd}	Gate-Drain Charge			4.3		nC
V_{SD}	Diode Forward Voltage	$V_{GS}=0V, I_{SD}=-1A$		0.72	1.4	V

Note:

1. Repetitive Rating : Pulsed width limited by maximum junction temperature.
2. The data tested by pulsed , pulse width $\leq 300\mu s$, duty cycle $\leq 2\%$.
3. Essentially independent of operating temperature.

TYPICAL ELECTRICAL AND THERMAL CHARACTERISTICS

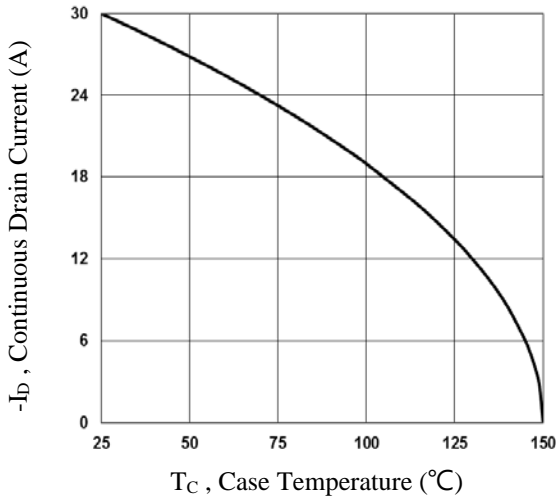

Fig.1 Continuous Drain Current vs. T_c

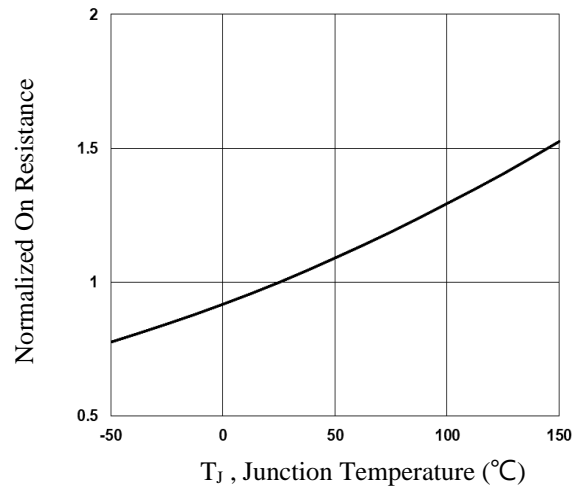

Fig.2 Normalized $R_{DS(on)}$ vs. T_j

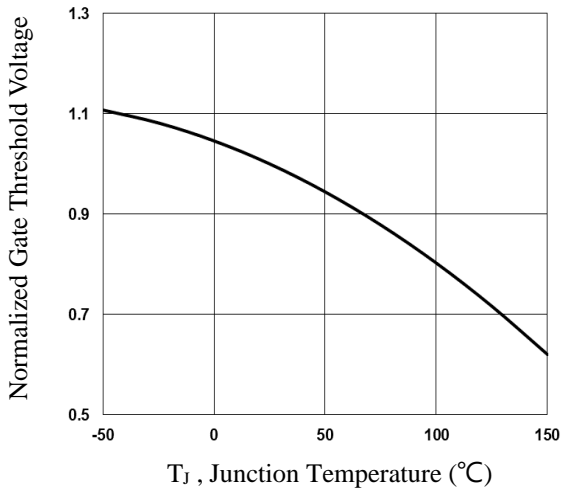

Fig.3 Normalized V_{th} vs. T_j

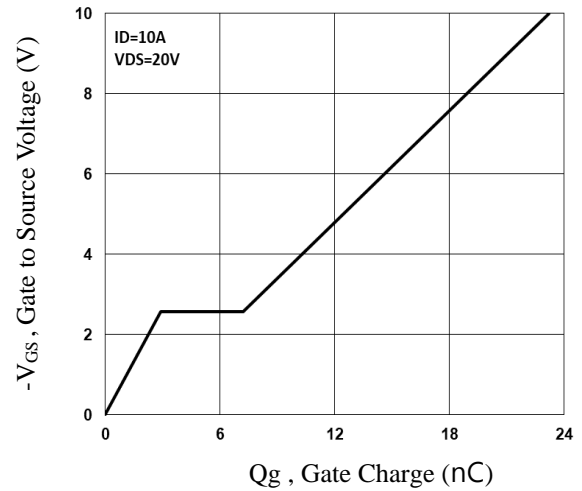

Fig.4 Gate Charge Waveform

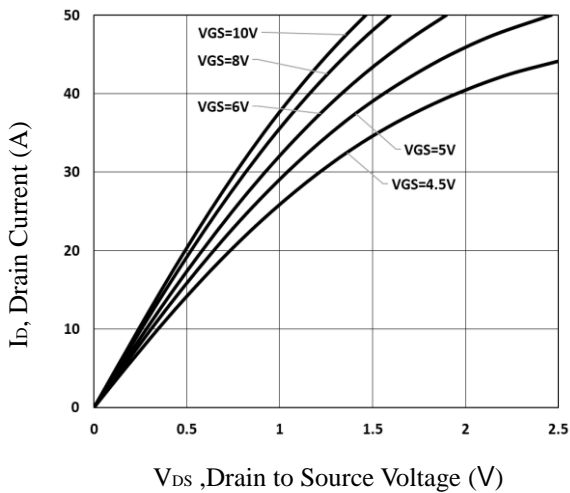

Fig.5 Typical Output Characteristics

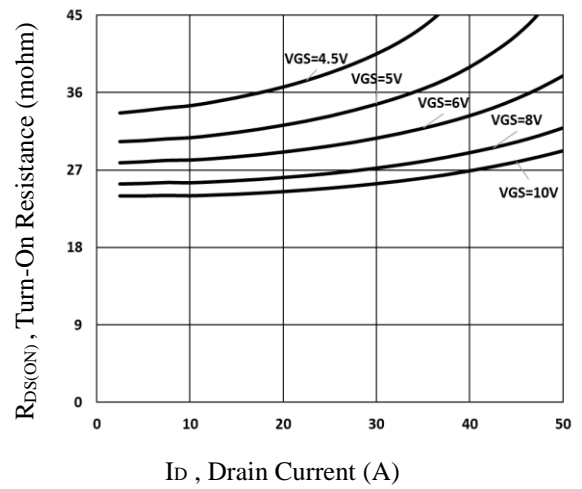

Fig.6 Turn-On Resistance vs. I_D

TYPICAL ELECTRICAL AND THERMAL CHARACTERISTICS

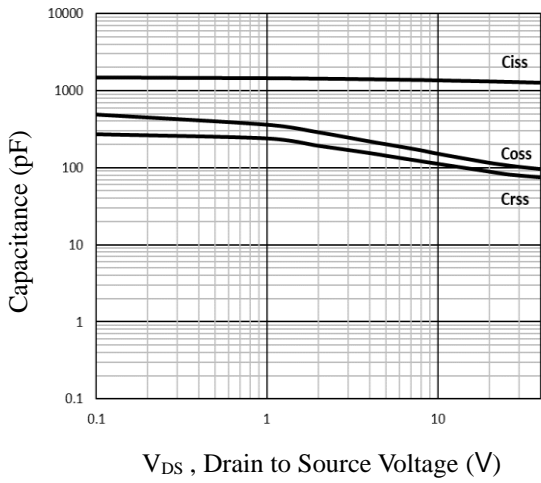

Fig.7 Capacitance Characteristics

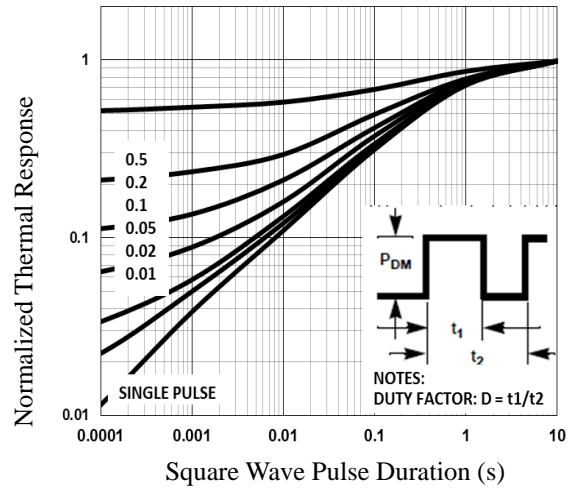

Fig.8 Normalized Transient Impedance

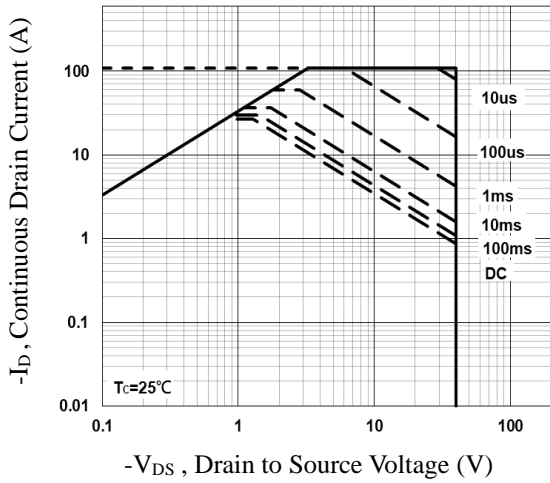
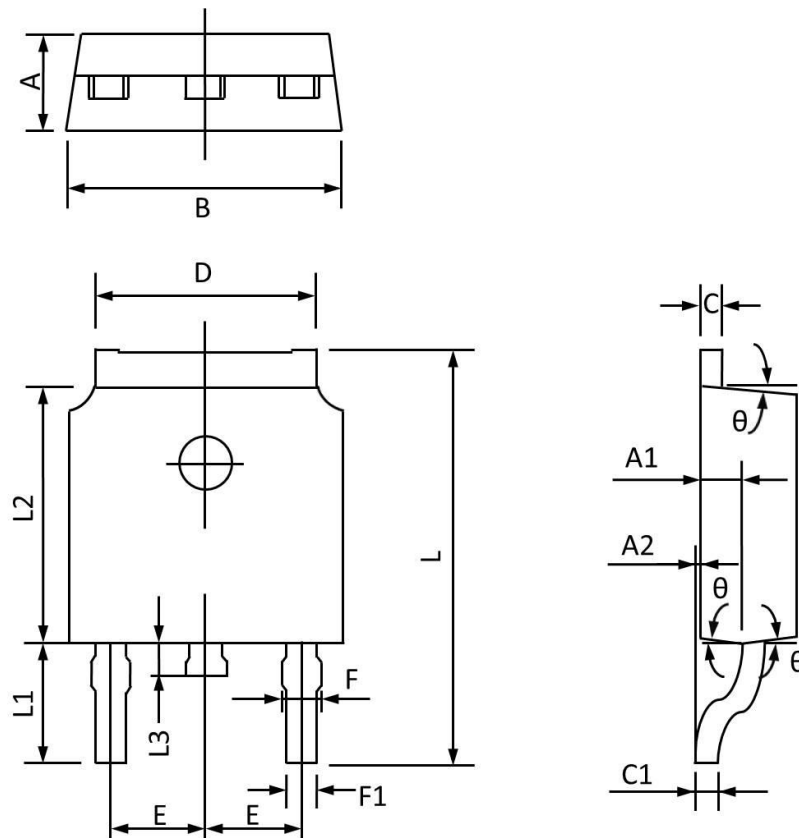

Fig.9 Maximum Safe Operation Area

TO252 PACKAGE INFORMATION



Symbol	Dimensions In Millimeters		Dimensions In Inches	
	Min	Max	Min	Max
A	2.20	2.40	0.087	0.094
A1	0.91	1.11	0.036	0.044
A2	0.00	0.15	0.000	0.006
B	6.50	6.70	0.256	0.264
C	0.46	0.580	0.018	0.230
C1	0.46	0.580	0.018	0.030
D	5.10	5.46	0.201	0.215
E	2.186	2.386	0.086	0.094
F	0.74	0.94	0.029	0.037
F1	0.660	0.860	0.026	0.034
L	9.80	10.40	0.386	0.409
L1	2.9REF		0.114REF	
L2	6.00	6.20	0.236	0.244
L3	0.60	1.00	0.024	0.039
θ	3°	9°	3°	9°